



DFD446

You can rely on Defy. To simplify.

EN

INSTRUCTION MANUAL

L60445 UPRIGHT FRIDGE

Record in the space below the listed information for future reference.

SERIAL NUMBER.....

DATE OF PURCHASE.....

PURCHASED FROM.....

.....

The manufacturer strives for continuous improvement. For this reason, the text and illustrations in this manual are subject to change without notice.

Part number:
4578335901

Read this manual before initial installation and operation of the appliance!

Dear Customer,

Your new Defy appliance was manufactured in a state of the art facility and has passed the strictest quality control procedures.

Please read this manual carefully before using your appliance for the first time and then store it within easy reach for future reference.

We trust you will enjoy years of trouble free use.

The user manual:

- This manual will provide you with information on how to safely operate and care for your appliance in order that you gain the maximum benefit from it.
- Pay particular attention to any safety instructions.
- Please read all additional documents supplied with your appliance.
- Please note that this manual may be used for several similar but different models. Please check for relevance regarding your particular model.

Explanation of symbols used in this manual



Important safety information. Warning for hazardous situations with regard to life and property.



Caution; Warning for supply voltage.



Caution; Warning for fire hazard.



Caution; Warning for hot surfaces.



Useful information. Important information or useful hints about usage.

Unpacking

Remove all packaging.

Ensure that packing material is disposed of in a responsible manner and that any plastic bags are cut up to prevent children playing with them and accidentally suffocating.

If the appliance is damaged in any way do not use it. Report the damage to your dealer who will take the necessary corrective action.

Please register your product at
www.defy.co.za
DEFY APPLIANCES (PTY) LTD
P.O.BOX 12004
JACOBS
DURBAN
4026
SOUTH AFRICA



Figures represented in this instruction manual are schematic and may not correspond exactly with your appliance. If the parts are not included in the appliance you have purchased, they may be model specific and therefore only valid for some models.

Contents

<u>1. Your Refrigerator</u>	4	<u>4. Preparation</u>	15
<u>2. Important Safety Information</u>	5	Adjusting the feet	16
Warnings	5	<u>5. Using your Refrigerator</u>	17
Electrical connection	7	Thermostat knob	17
Child safety	8	Using interior compartments	17
HCA Warning	8	Stopping the appliance	17
For appliances with a water dispenser	9	Food storage	18
Energy saving tips	10	Defrosting the appliance	18
Owners responsibility	10	<u>6. Maintenance and cleaning</u>	19
<u>3. Placing and Installation</u>	11	<u>7. Trouble Shooting</u>	20
Transportation instructions	11	<u>8. Service Centres</u>	23
Installation instructions	12	<u>9. Warranty</u>	24
Reversing the doors	13		



Warning: Do not place any copper pots or dishes inside the cabinet.



Figures in this manual are schematic and may not match your appliance exactly.

Values stated on the machine labels or in the documentation accompanying it are obtained in laboratory conditions in accordance with the relevant standards. Depending on operational and environmental conditions of the machine, these values may vary.

1 Your Refrigerator

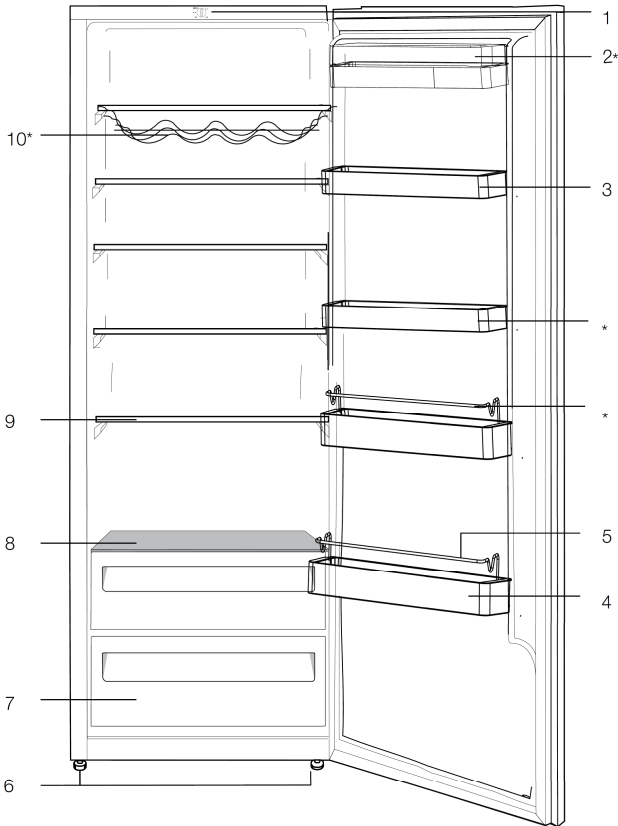

- 1. Trim plastic front
- 2. Butter & Cheese sections
- 3. Adjustable door shelves
- 4. Bottle shelves
- 5. Shelter wire

- 6. Adjustable front feet
 - 7. Chiller
 - 8. Chiller cover and glass
 - 9. Movable shelves
 - 10. Wine cellar
- * (Depends on Model).



The manufacturer strives for continuous improvement. For this reason, technical specifications, text and illustrations in this manual are subject to change without notice.

Figures represented in this instruction manual are schematic and may not correspond exactly with your appliance. If the parts are not included in the appliance you have purchased, they may be model specific and therefore only valid for some models.



2 Important safety information

Please review and observe the following information. Failure to do so may result in injuries or material damage and will render any warranty and reliability commitments void. Spare parts for the appliance will be stocked for 10 years to meet any maintenance or service requirements.

Warnings

- Hand this owners manual over to the new owner should ownership change.
- The appliance must only be used for its intended purpose, i.e. the storing of edible foodstuff.
- The appliance is intended to be used in household and similar applications such as :
 - Staff kitchen areas in shops,
 - Offices and other working environments;
 - Farm houses and by clients in hotels, motels and other residential type environments; bed and breakfast type environments; catering and similar non-retail applications.
- Consult with your authorised DEFY service centre for all questions and problems relating to the appliance. Only authorised agents are to carry out repairs.
- Vapour and vaporized cleaning materials must never be used in the cleaning and defrosting the appliance. The vapour may come into contact with the electrical parts and cause a short circuit or electric shock.
- This appliance is not intended for use by persons (including children) with reduced physical, sensory or mental capabilities or lack of experience and knowledge, unless they have been given supervision or instruction concerning the use of the appliance by a person responsible for their safety.
- Children should be supervised to ensure that they do not play with the appliance.
- Do not allow children to hang on the appliance door as the unit could topple forward risking personal injury. Never use the parts on your appliance, such as the door, as a means of support or step.
- Do not use electrical appliances inside the appliance.
- Keep ventilation openings, in the appliance or in the built-in structure, clear of obstructions.

- Unplug the appliance when cleaning, during routine maintenance or if it will not be used for an extended period.
- To unplug the appliance, remove the plug by pulling on the plug and not the cable!
- Exposing the appliance to rain, snow, sun and wind is an electrical safety risk.
- Should the mains lead of the appliance become damaged or should it need replacing at any time, it must be replaced by a special purpose made mains lead which can only be obtained from a DEFY Authorised Service Agent.
- Never connect your appliance to electricity saving systems as they may damage the appliance.
- Do not store medicine or academic research samples which require strict temperature control in the appliance.
- Do not store or use flammable gas, benzene, petrol or volatile substances in or near the appliance.
- Do not store explosive substances such as aerosol cans with a flammable propellant in the appliance.
- In the event of a malfunction, disconnect the appliance from the power supply.
- Do not overload your appliance with excessive amounts of food. If overloaded, the food items may fall down and injure you and damage the appliance when you open the door. Never place objects on top of the appliance, they may fall down and injure you when you open or close the appliance door.
- If there is a blue light fitted on the appliance, do not look at the blue light through optics.

	Do not operate a damaged appliance. Consult with your nearest DEFY service Centre should you have any concerns
	The electrical safety of the appliance is only guaranteed if the earth system of your home is compliant to national standards.
	Never plug the appliance into the wall socket during installation. Death or serious injury may result.

- The appliance may move if the adjustable legs are not properly levelled on the floor. Levelling the adjustable legs on the floor helps prevent the appliance from moving.
- When carrying the appliance, do not hold on the door handle as this may cause the handle to break.
- When placing your appliance next to another appliance or freezer, the distance between the devices should be at least 25 mm. Failure to do so may cause adjacent walls to humidify.
- For appliances with a freezer compartment; Do not put bottled and canned liquid beverages in the freezer compartment as they may burst.
- Do not touch frozen food with your hands; they may stick to your hand.
- Never pour or spray water into or on the appliance and do not store liquids, pot plants or open containers on top of the appliance as these might spill causing electrical shorting.
- For manually controlled appliances, wait at least 5 minutes before starting the appliance after a power failure.
- Avoid any damage to the power cable when transporting the appliance.

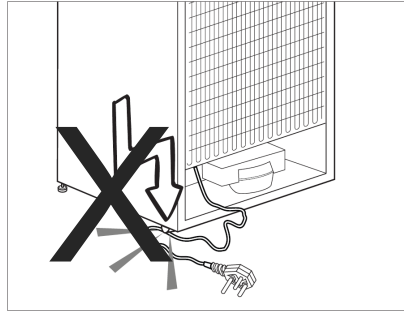

- Bending the cable may cause a fire.
- Never place heavy objects on the power cable.
- Do not touch the plug with wet hands.
- Do not plug in the appliance if the wall socket is loose.
- On delivery, check to make sure that the appliance is not damaged and that all the parts and accessories are in perfect condition.
- Ensure that the plug remains readily accessible. Do not use multiple adapter plugs or an extension cable.
- Ensure that there is sufficient spacing between the appliance and surrounding walls.
- Unplug the appliance from the mains when you clean the appliance.

Electrical connection

Connect your appliance to a grounded socket which is protected by a fuse with the appropriate capacity.

Important

The connection must be in compliance with national regulations.

The power cable plug must be easily accessible after installation.

The specified voltage must be equal to your mains voltage.

Child safety

- If the door has a lock, the key should be kept out of reach from children.
- If you are discarding an old appliance with a lock or latch fitted to the door, disable the lock/latch, and ensure that the appliance is left in a safe condition to prevent children from being trapped inside and suffocating.
- Children must be supervised to prevent them from tampering with the appliance.



HCA Warning



Refrigerator cooling systems containing R600a:

At DEFY, the care and protection of our environment is an on going commitment. This DEFY refrigerator is particularly environmentally friendly and contains non CFC / HFC natural substances in the cooling system (Called R600a) and in the insulation (Called cyclopentane).

These are potentially flammable if exposed to fire. Take care not to damage, the cooling circuit / pipes of the refrigerator in transportation and in use. In case of damage do not expose the refrigerator to fire or potential ignition sources and immediately ventilate the room where the refrigerator is situated.

Ignore this warning if your refrigerators cooling system contains R134a.

	Warning: Never dispose of the Appliance in a fire.
	Do not dispose of your Appliance along with regular household waste.
	Contact your local authority for disposal information and facilities available.
	Do not drill, cut or modify the appliance. Injuries may result if the refrigerant circuit is damaged. See HCA warning. Do not damage the refrigerant circuit.
	Repairs must be carried out by authorised persons only. Repairs carried out by incompetent persons create a user risk.

	<p>The front edges of the appliance may feel warm. This is normal. These areas are designed to be warm in order to avoid condensation.</p>
	<p>A damaged appliance must not be operated before it is repaired! There is danger of an electric shock!</p>
	<p>DEFY declines to accept any liability should the instructions not be followed.</p>

For appliances with a water dispenser (Depends on model)

In order to operate the water circuit of the appliance smoothly, the water mains pressure must be between 1-8 bars. For conditions where water mains pressure exceeds 5 bars a pressure regulator should be used. If the water mains pressure exceeds 8 bars then the appliance's water circuit should not be connected to the water mains. If you lack the knowledge of how to measure the water mains pressure, please seek a professional support. Use drinking water only.

Use only potable water.

Energy saving tips

- Ensure your appliance is installed in a well ventilated area. If the ambient temperature is low (but in no case lower than 5°C), then the energy saving will be more. Do not install your appliance under direct sunlight or near heat emitting appliances such as ovens, dishwashers or radiators. Keep food in closed containers.
- Ensure the time between buying chilled/ frozen food and placing it in the appliance is kept at a minimum, particularly in summer. Use a cooler bag or a special carrier bag to carry frozen food. Do not put hot food or drinks in the appliance.
- Do not leave the door of the appliance open for long and ensure it is closed properly after each opening.
- Do not put hot food or drinks in your appliance.
- Do not overload your appliance. This restricts effective air circulation in the appliance.
- Pay attention to keep your food in closed containers.

Owner's responsibility

Do not use electrical appliances inside the food storage compartments of the appliance, unless they have been recommended by the manufacturer.

Since the following are not factory faults they are the owners responsibility:

- Damage to the exterior finish.
- Breakage of glass and other components.
- Replacement of light bulbs.
- Damage caused through improper use of the appliance.
- Damage caused by moving the appliance.

3 Placing and Installation

Transportation instructions

1. The appliance should be transported only in a vertical upright position. The packing as supplied must be intact during transportation.
2. If during the course of transporting the appliance has to be transported horizontally, it must only be laid on its right hand side when standing in the front of the appliance. After bringing it to the upright position, it must not be operated for at least 4 hours to allow the system to settle.
3. Failure to comply with the above instructions could result in damage occurring to the appliance. The manufacturer will not be held responsible if these instructions are disregarded.
4. The appliance must be protected against rain, moisture and other atmospheric influences.

Important: Make sure the plastic evaporating pan at the back of the appliance collects water properly.

Important: Care must be taken while cleaning / carrying the appliance to avoid touching the bottom of the condenser metal wires at the back of the appliance as you may injure your fingers or hands.

When re-transporting your appliance

- Your appliance must be emptied and cleaned prior to any transportation.
- The accessories in your appliance must be fastened securely with adhesive tape to protect against any jolts.
- Packaging must be tied with thick tape and strong rope and the transportation guidelines printed on the package must be followed.

Important: This appliance is not designed for stacking with any other appliance.

When positioning your appliance, take care not to damage your flooring, pipes, wall coverings etc.

Do not move the appliance by pulling on the door handle.

Do not attempt to sit or stand on top of your appliance as it is not designed for such use. You could injure yourself or damage the appliance.

Important: Make sure that the mains cable is not caught under the appliance during and after carrying / moving the appliance. To avoid the mains cable becoming cut or damaged. Do not allow children to play with the appliance or tamper with the controls. Defy declines to accept any liability should the instructions not be followed.

Installation Instructions

1. The space in the room where the appliance is installed must not be smaller than 10 cubic metres.
2. If possible avoid placing the appliance near cookers, radiators or in direct sunlight as this will cause the compressor to run for long periods. If installed next to a source of heat or refrigerator, maintain the following minimum side clearances:
From Cookers 50 mm
From Radiators 300 mm
From Refrigerators or Freezers 25 mm
3. Make sure that sufficient room is provided around the appliance to ensure free air circulation. Allow a minimum of 60 mm between the top of the appliance and the ceiling or the underside of a wall cupboard.
4. Fit the two plastic wall spacers supplied onto the condenser at the back of the appliance by rotating them 1/4 turn.

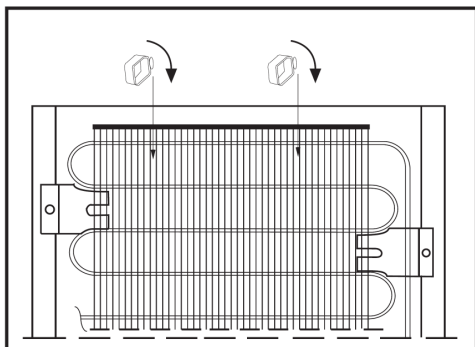

5. The appliance should be located on a smooth surface. The two front feet can be adjusted as required. To ensure that your appliance is standing upright adjust the two front feet by turning clockwise or anti-clockwise, until the appliance is in firm contact with the floor. Correct adjustment of feet avoids excessive vibration and noise.
6. Refer to "Cleaning and Care" section to prepare your appliance for use.
7. The appliance must be protected against rain, moisture and other atmospheric influences.

8. A special receptacle is supplied to store the mains plug during transit. The receptacle is fixed at the back of the cabinet, on the right hand side of the compressor. (See diagram) Gently remove the plug from the receptacle.

Never pull the mains cord, you may damage the appliance.

In the case of transportation, ensure you locate the plug in the receptacle provided to avoid transit damage.

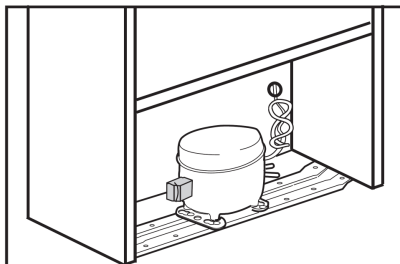

If the floor is covered with a carpet, your appliance must be elevated 25 mm from the floor.

Reversing The Doors

We recommend that you reverse doors (if required) before switching on for the first time.

	<p>Important: Have somebody to assist you when moving the appliance and to hold the doors when removing / re-fitting hinges and doors to avoid injury and damage to the appliance</p>
---	--

Please refer to diagrams supplied.

	<p>Figures represented in this instruction manual are schematic and may not correspond exactly with your appliance.</p> <p>If the parts are not included in the appliance you have purchased, they may be model specific and therefore only valid for some models.</p>
--	--

Reversing the doors
Proceed in numerical order

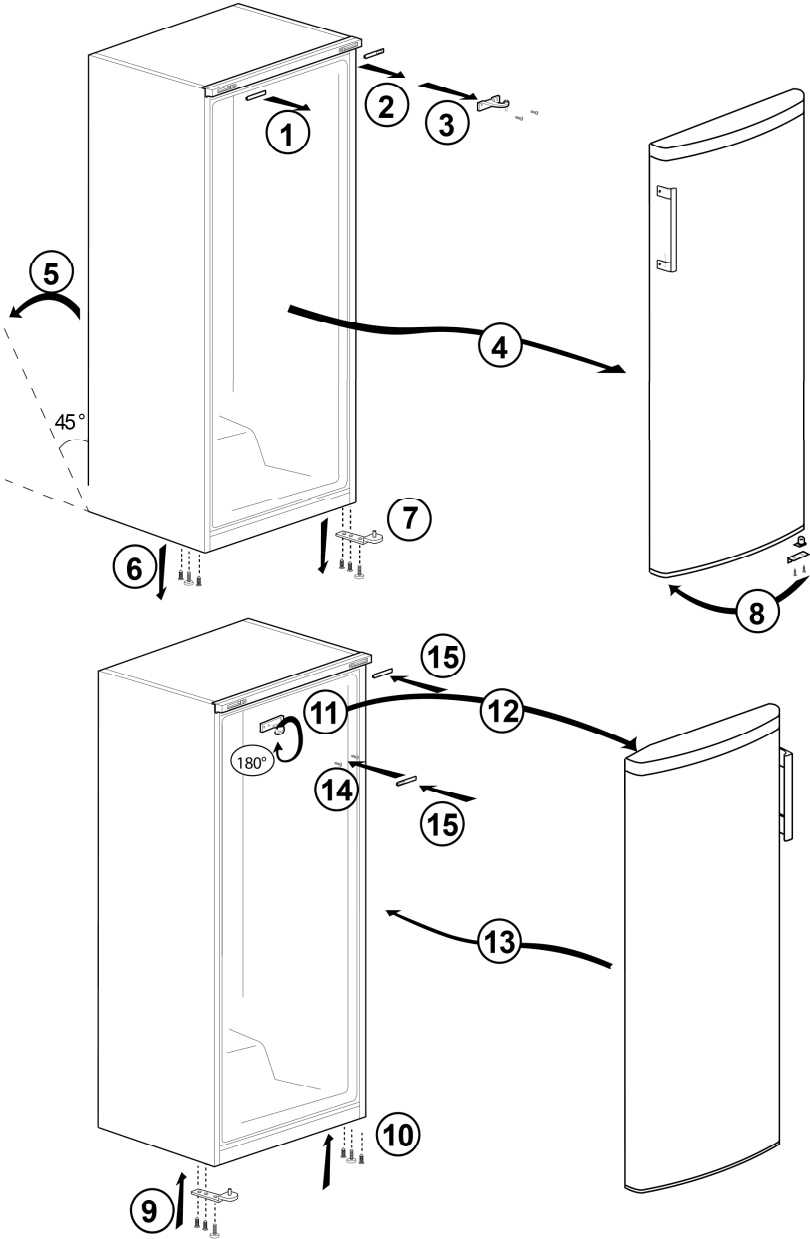

4 Preparation

Your refrigerator should be installed at least 300 mm away from heat sources such as hobs, ovens, central heater and stoves and at least 50 mm away from electrical ovens and should not be located under direct sunlight.

- Please make sure that the interior of your refrigerator is cleaned thoroughly.
- If two coolers are to be installed side by side, there should be at least 25 mm distance between them.
- When you operate your refrigerator for the first time, please observe the following instructions during the initial six hours:
 - Its door should not be opened frequently.
 - It must be operated empty without placing any food in it.
 - Do not unplug your cooler.
 - This refrigerator has been designed to function at ambient temperatures up to 43 °C (90 SDgrF). For the first installation, the refrigerator should NOT be placed under low ambient temperatures. When reaching continuous operation, the refrigerator can be moved to another area.
- If the ambient temperature is below 0°C, the food in the fridge will freeze.

Adjusting the feet

The appliance may move if the adjustable legs are not properly levelled on the floor.

Levelling the adjustable legs on the floor:

Level your appliance by turning the front legs as shown in the illustration below.

The corner where the legs are is lowered when the leg is turned in the direction of the black arrow and raised when turned in the opposite direction.

Having someone to carefully assist in tilting the appliance slightly will help facilitate this process.

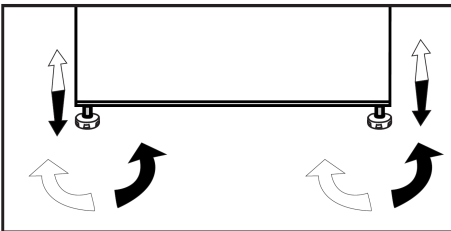

Changing the illumination lamp

To change the Bulb/LED used for illumination of your refrigerator, call your Authorized Service.

Door Open Warning (Depends on model)

An audio warning signal will be given when the door of your product is left open for at least 1 minute. This warning will be muted when the door is closed or any of the display buttons (if any) are pressed.

5 Using your Refrigerator

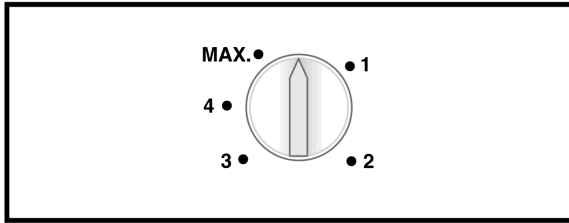

Thermostat knob

The thermostat knob is located on the top trim of the cooler/freezer.

Stopping your appliance

Please turn the thermostat knob to position "1" Unplug your product to stop it.

Important:

When you adjust the set temperature, there may be a short delay before the compressor starts to operate. This is normal and not a compressor fault.

Using interior compartments

Body shelves: Distance between the shelves can be adjusted when necessary.

Crisper: Vegetables and fruits can be stored in this compartment for long periods without decaying.

Bottle shelf: Bottles, jars and tins can be placed in these shelves.



Important:

When you adjust the set temperature, there may be a short delay before the compressor starts to operate. This is normal and not a compressor fault.

Food storage

The fridge compartment is for the short term storage of fresh food and drinks.

Store milk products in the intended compartment in the cooler.

Bottles can be stored in the bottle holder or in the bottle shelf of the door. Raw meat is best kept in a polyethylene bag in the compartment at the very bottom of the cooler.

Allow hot foods and beverages to cool to room temperature prior to placing them in the cooler.

Attention

Store concentrated alcohol only standing upright and tightly closed.

Attention

Do not store explosive substances or containers with flammable propellant gases (canned cream, spray cans etc.) in the device. There is a danger of explosion.

Placing foods	
Egg holder.	Eggs.
Fridge compartment shelves.	Food in pans, covered plates and closed containers.
Fridge compartment door shelves.	Small and packaged food or drinks (such as milk and fruit juice). Delicatessen products.
Crisper.	Vegetables and fruits.

Defrosting the appliance

The appliance defrosts automatically.

6 Maintenance and Cleaning

1. **Always disconnect the plug from the mains socket before cleaning.**
2. Never use any sharp instruments or abrasive substances, soap, household cleaner, detergent or wax polish for cleaning.
3. Use luke warm water to clean the cabinet of the appliance and wipe it dry.
4. Use a damp cloth wrung out in a solution of one teaspoon of bicarbonate of soda to two litres of water to clean the interior and wipe it dry with a soft cloth.
5. Make sure that no water enters the lamp housing and other electrical items.
6. If the appliance is not going to be used for a long period of time, switch it off and unplug the power cable, remove all food, clean it and leave the door ajar.
7. Check door seals regularly to ensure they are clean and free from food particles.
8. **Never:**
 - Clean the appliance with unsuitable material; e.g. petroleum based appliances.
 - Subject it to high temperatures in any way,
 - Scour, rub etc., with abrasive material.
9. Spillages, especially citric and acidic juices, must be wiped up immediately as they could stain the interior of the appliance. Shelves and freezer baskets, where fitted, may be removed for cleaning purposes.

Protection of plastic surfaces

Do not place liquid oils or oil-cooked meals in your appliance in unsealed containers as they may damage the plastic surfaces. In case of spilling or smearing oil on the plastic surfaces, clean and rinse the relevant part of the surface at once with warm water.



Warning: Do not damage the refrigerant circuit. Do not use electrical appliances inside the food storage compartments of the appliance, unless they have been recommended by the manufacturer.

Warning: Repairs must be carried out by authorised persons only. Repairs carried out by incompetent persons create a user risk.

7 Trouble Shooting

Please review this list before calling a service centre. It could save you time and money. This list includes frequent complaints that do not arise from defective workmanship or material usage. Some of the features described here may not apply to your model.

Symptom	Check
The appliance does not operate.	<ul style="list-style-type: none">• Make sure the appliance plug is securely plugged in.• Check for a blown fuse or tripped circuit breaker.• Test the wall socket for power using another appliance.• Inspect the electrical cord for damage.• Eliminate the use of an extension cord, if any is being used.
Condensation on the side wall of the fridge compartment.	<ul style="list-style-type: none">• Very cold ambient conditions. Frequent opening and closing of the door. Highly humid ambient conditions. Storage of food containing liquid in open containers. Leaving the door ajar. Switching the thermostat to a colder degree.• Decreasing the amount of time the door is left open or using it less frequently.• Covering the food stored in open containers with a suitable material.• Wipe the condensation using a dry cloth and check if it persists.
Compressor is not running.	<ul style="list-style-type: none">• The protective thermal relay of the compressor will blow out during sudden power failures or plug-outs and plug-ins as the refrigerant pressure in the cooling system of the appliance has not yet been balanced. Your appliance will start running approximately after 15 minutes. Please call a service centre if the appliance does not start up at the end of this period.• The appliance is in defrost cycle. This is normal for an automatic defrosting appliance. The defrosting cycle occurs periodically.• Your appliance is not plugged into the wall socket. Make sure that the plug is properly fitted into the wall socket.• Have the temperature adjustments been correctly made?• Power might be cut off.
Condensation on the inner walls of appliance.	<ul style="list-style-type: none">• Hot and humid weather increases icing and condensation. It is normal and not a fault.• Doors might have been left ajar; ensure the doors are fully closed.• Doors might have been opened frequently or left ajar for a long time; open them less frequently.

Symptom	Check
Temperature in the fridge is very high.	<ul style="list-style-type: none"> • The fridge temperature might have been adjusted to a very high degree. Change the temperature of the fridge until the fridge temperature reaches a sufficient level. • Doors might have been opened frequently or left ajar for a long time; open them less frequently. • Door might have been left ajar; close the door completely. • Large amount of hot food might have been put in the appliance recently. Wait until the fridge or freezer reaches the desired temperature. • The appliance might have been plugged in recently. Complete cooling down of the appliance takes time.
The fridge is running continuously or for a long time.	<ul style="list-style-type: none"> • Your new appliance may be wider than the previous one. This is quite normal. Large appliances operate for a longer period of time. • The ambient room temperature may be high. This is quite normal. • The appliance might have been plugged in recently or might have been loaded with food. Cooling down of the appliance completely may last for a couple of hours longer. • Large amounts of hot food might have been put in the appliance recently. Hot food causes longer running of the appliance until the food has cooled down. • Door might have been opened frequently or left ajar for a long time. The warm air that has entered into the appliance causes the appliance to run for longer periods. Open the door less frequently. • The freezer or fridge compartment door might have been left ajar. Check that the doors are tightly closed. • The appliance is adjusted to a very low temperature. Adjust the appliance temperature to a warmer degree and wait until the temperature is achieved. • The door seal of the fridge or freezer may be soiled, worn out, broken or not properly seated. Clean or replace the seal. A damaged/broken seal causes the appliance to run for a longer period of time in order to maintain the current temperature.
Humidity occurs on the outside of the appliance or between the doors.	<ul style="list-style-type: none"> • There might be humidity in the air; this is quite normal in humid weather. When the humidity is less, condensation will disappear.
Bad odour inside the appliance.	<ul style="list-style-type: none"> • The inside of the appliance must be cleaned. Clean the inside of the appliance with a sponge, lukewarm water or carbonated water. • Some containers or package materials might cause the smell. Use a different container or different brand of packaging material.

Symptom	Check
Crispers are stuck.	<ul style="list-style-type: none"> • The food might be touching the ceiling of the drawer. Rearrange the food in the drawer.
The door is not closing.	<ul style="list-style-type: none"> • Food packages may prevent the door's closing. Repack the packages that are obstructing the door. • The appliance is not completely level on the floor and rocks when slightly moved. Adjust the elevation screws. • The floor is not level or strong. Make sure that the floor is level and capable of carrying the weight of the appliance.
Noise like wind blowing.	<ul style="list-style-type: none"> • Fans are used to cool the appliance. It is normal and not a fault.

	<p>Warning: Repairs must be carried out by authorised persons only. Repairs carried out by incompetent persons create a user risk.</p>
--	---

	<p>DANGER! Always disconnect the plug from the wall socket before any maintenance or cleaning.</p>
---	---

Service Centres

If you have followed the instructions and still have a problem, contact the nearest Defy Service Centre. They will be able to advise you on any aspect of the appliance or send a qualified technician to repair it.

South African Service Agents:

BLOEMFONTEIN

160 Long Street, Hilton, Bloemfontein 9301
Tel: 051 400 3900
Bloemfontein.Service@defy.co.za

CAPE TOWN

5A Marconi Rd. Montague Gardens, 7441
Tel: 021 526 3000
CapeTown.Service@defy.co.za

DURBAN

35 Intersite Avenue, Umgeni Business Park,
Durban, 4051
Tel: 031 268 3300
Durban.Service@defy.co.za

EAST LONDON

16 Bowls Rd. Arcadia, East London, 5201
Tel: 043 743 7100
EastLondon.Service@defy.co.za

JOHANNESBURG

Cnr. Mimetes & Kruger Sts. Denver ext.12
Johannesburg, 2094
Tel: 011 621 0200 or 011 621 0300
Gauteng.Service@defy.co.za

POLOKWANE

87 Nelson Mandela Drive, Superbia 0699
Tel: 0152 92 1166 / 7 / 8 / 9
Polokwane.Service@defy.co.za

PORT ELIZABETH

112 Patterson Road, North End, Port Elizabeth
6001
Tel: 041 401 6400
PortElizabeth.Service@defy.co.za

PRETORIA

Block A1 Old Mutual Industrial Park,
Cnr. D.F.Malan Drive & Moot Str. Hermanstad,
0082
Tel: 012 377 8300
Pretoria.Service@defy.co.za

Sub-Saharan Africa Service Agents:

ZAMBIA: SOUTHGATE INVESTMENTS LTD

Plot 1606, Sheki Sheki Road
P.O. Box 33681
Lusaka, 10101, Zambia
Tel: +260 0211 242332/3
Fax: +260 0211 242933
sgiservicecentre@microlink.zm

NAMIBIA: ATLANTIC DISTRIBUTORS (PTY) LTD

10 Tienie Louw Street, Northern Industrial Area
P.O. Box 21158, Windhoek, Namibia
Tel: (061) 216162
Fax: (061) 216134
atlantic@mweb.com.na

ZIMBABWE: TRADECOMAFRICA

Trade Com Africa, 183 Loreley Crescent
Msasa, Harare, Zimbabwe
Tel: +263 4 486165/6
Cell: +263 772 469010
Cell: +263 772 469011

BOTSWANA: RAY MORGAN AGENCIES

RMA Service Centre, Plot 48, East Gate
Gaborone International Commerce Park
Kgale View, Gaborone
Botswana
Tel: +267 390 3996 / 390 3912
Fax: +267 318 7376
Cell: +267 7134 6539
service@rma.co.bw; raja@rma.co.bw

SWAZILAND: LYNDS DISTRIBUTORS

P.O Box 716, Mbabane, Swaziland, H100
Tel: (00268) 2515 4310/8
Fax: (00268) 2518 4318

MOZAMBIQUE: COOL WORLD. LDA

Rua da Resistencia No. 97B R/C
Cell: +258 84 44 61 234
coolworldlda@hotmail.com
Nosso Show Room
Av: da Industrias, Parcela No.735 * 735A
Machava, Maputo

**OTHER AREAS ARE SERVICED BY OVER 200 AUTHORISED SERVICE AGENTS.
PLEASE CONSULT THE NEAREST REGIONAL DEFY SERVICE CENTRE FOR DETAILS.**

9 Warranty

This certificate is issued by DEFY APPLIANCES (PTY) LIMITED manufacturers of Defy and Ocean products, hereinafter the Company, to the original purchaser only, of the appliance described on the certificate and shall constitute the only warranty given in respect of this appliance.

The Company warrants to the original purchaser that for a period of TWO YEARS from date of purchase the appliance is free from defect under normal domestic use, both in workmanship and material, subject to the following conditions.

1. Repair or replacement of any part of this appliance, found by the Company to be defective, shall be at the election of the Company. The Company reserves the right to effect such service through any of its Service Divisions or Authorised Service Dealers. The cost of such service shall be borne by the Company in full, provided that the appliance is located no further than 50km from a Company Service Centre or an Authorised Service Dealer. Where the appliance is located beyond the 50km radius, the purchaser shall be liable for the standard travelling charges, as determined by the Company.
2. Vitreous enamelware, fuses and lamps are specifically excluded from these warranties. It is an express condition of these warranties that the purchaser takes due care and attention in the use and maintenance of the appliance. Abuse, misuse in conflict with operating instructions, connection to incorrect voltages and subjection to commercial use shall release the Company from its obligations.
3. This warranty shall become void and cease to operate if the appliance is dismantled by, or any repairs to the appliance are effected by any persons not duly authorised by the Company, or if substitute parts not approved by the Company are used in the appliance, or if the serial number of the appliance is removed.
4. The Company shall not be responsible for damages resulting from fire, flood, civil disturbances or any Act of God. The Company shall not, in terms of these warranties be responsible nor held liable for any consequential loss or damage of any kind caused by or due to the failure or malfunction of the appliance.
5. The Company shall not be responsible for transportation or other costs other than those incurred within the provisions of Point 1 of this Certificate.
6. **For warranties in the Republic of South Africa and Sub-Saharan Africa, please contact your nearest Defy office. Please refer to the previous page for respective South African service agents and Sub-Saharan Africa service agents.**
7. Where service is requested under warranty and no fault or defect can be found by the Company, all costs incurred will be for the purchaser's account.
8. This Certificate as well as your invoice will serve as proof of purchase. For the purpose of warranty, it will be essential to produce this Certificate and invoice. Failure to do so, will render the purchaser liable for service costs.

KEEP THIS CERTIFICATE AND SALES INVOICE AS PROOF OF PURCHASE FOR WARRANTY PURPOSES.